



AMERICAN EAGLE[®]
FOOD MACHINERY, INC.

AE-GMC22N *High Volume Meat Cutter Kit*

773.376.0800 (P) • 773.376.2010 (F) • 3131 S. Canal St. Chicago, IL 60616

Introducing the new AE-GMC22N 1.5 HP High Volume Meat Cutter Kit. Designed with a larger 7" x 2" feed chute and longer blade shafts to slice even larger pieces of meat quickly and efficiently.

New And Improved Design

- Powerful 1.5 HP Motor
- Fixed Blade Spacing, Four Output* Sizes Available: 1/2", 1", 1 1/2", 2"
- 100% Durable Steel Alloy Gear Driven Transmission
- Low Maintenance, Permanently Lubricated, Sealed Motor For Food Safety
- Heavy Duty, Single Piece Combs Prevent Meat From Becoming Trapped Between Blades
- Ball Bearing Mounted Stainless Steel Shafts For High Volume Processing And Extra Smooth Operation
- Easy To Clean, Seamless, Attractive, High Polish Stainless Steel Housing
- Extra Large, 7"L x 2"W Input Chute Accommodates Thick Cuts Of Meat**
- Fine Adjustments Ensure Blades Touch For The Best Cutting Performance



Standard Features

- Forward/Reverse Switch**
- Mounted Blade Adjustment Knobs
- Motor Overload Protection With Reset
- Standard #12 Hub For Attachments
- 1 Year Parts / 1 Year Labor***

Optional Accessories

- AE-G12NH Meat Grinder
- AE-TS12H Meat Tenderizer
- AE-VS12NH Vegetable Cutter
- AE-JS12H Jerky Slicer
- AE-MC12NH Meat Cutter



AE-G12NH



AE-TS12H



AE-VS12NH



AE-JS12H



AE-MC12NH

Proud Member of:

 North American Association of
 Food Equipment Manufacturers

Quality • Value • Reliability



AMERICAN EAGLE[®]
FOOD MACHINERY, INC.

AE-GMC22N High Volume Meat Cutter Kit

sales@ameagle.biz • www.americaneaglemachine.com

Included Attachment

- High Volume AE-GMC22NH Meat Cutter Attachment
- Longer Input Chute And Longer Blade Shafts Than The Original AE-MC12NH
- Stainless Steel Feeder Pan Included
- Designed to Fit Universal #12 Hub
- Heavy Duty Combs Prevent Trapped Meat

Ideal For

- Skirt Steak
- Boneless Chuck
- Tough Game Meat
- Fajita Meat
- Chicken Breast

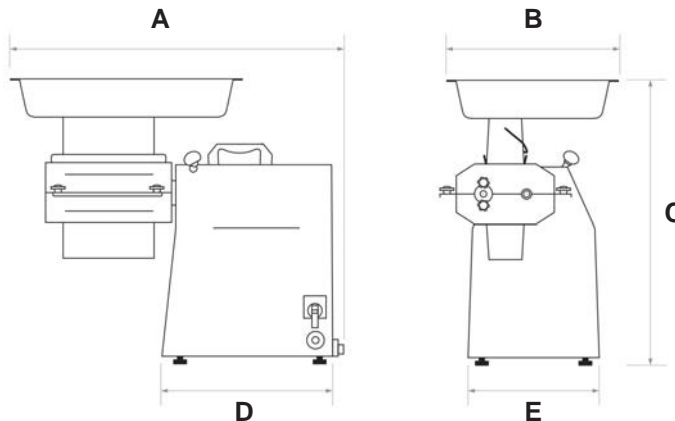

Dimensions	
A	22" (56 cm)
B	11.5" (29 cm)
C	19.25" (49 cm)
D	12.25" (31 cm)
E	9.67" (25 cm)

Specifications and Shipping Information

Model	Motor	Amps	RPMs	Voltage V/HZ/PH	Input Chute	Blade Diameter	Net Weight	Shipping Dimensions [#]	Ship Weight [#]
AE-GMC22N	1.5 HP	16	170	115/60/1	7" x 2"	3.5"	77.2 lbs	25" L x 16" W x 22" H	81.6 lbs

* ¼" model available at extra cost. Spacing is fixed and not adjustable, size must be selected when ordering.

** Feeding bones through the meat cutter will void warranty. Reverse mode should only be used with meat grinder head, using reverse on any other attachment may cause damage not covered by warranty.

*** Warranty must be registered. Please refer to manual on proper assembly. Improper use voids warranty. 1 year labor warranty only applies to machines manufactured starting from 2016. Warranty does not cover accessories such as combs or wear and tear items such as knives or blades.

**** Meat Cutter Attachment is hand wash only, A wire brush or air compressor is recommended to thoroughly clean in between the blades.

[#] May Ship In Two Boxes, Estimated Combined Dimensional Weight



Quality • Value • Reliability